

Quick Disconnect Coupling
Bayonet Type

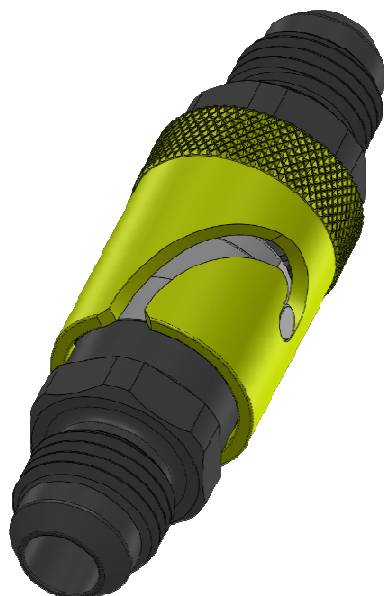

1. General information, scope

Date:	22.08.2011	Title:	Product Bulletin Bayonet-Type_08M-2011
System:	Quick disconnect couplings Bayonet-Type		
Customer:	All		
Part-no.:	All Bayonet-Types	Serial-Nr.:	none

2. Description and scope of application

The Quick Disconnect Couplings of the series Bayonet-Type are compact and lightweight couplings, developed for hydraulic and pneumatic purposes in motor sport with operating pressure up to 200bar.

Both halves, coupler and nipple, are equipped with self-acting valves to avoid loss of fluid during uncoupling as well as air inclusion during coupling.

The locking mechanism with bayonet is designed for one-hand operation with pushing and twisting the outer sleeve and no separate actuation is required for operation.

3. Seal materials, representative fluids

The standard sealing material is a modified fluorinated rubber compound (FPM, FKM, Viton), which is signed with the appendix "B". This new material is available in Quick Disconnect Couplings from SF Motorsporttechnik and also allows the use for fuel-alcohol mixtures, pure ethanol and vegetable oil.

Other materials as nitrile rubber (NBR), Ethylene-Propylene-Dien-rubber (EPDM) are available on request.

The operating temperatures are the following, dependent upon sealing material:

Material	Chemical description	Operating temperatures	Representative fluids
FKM B	Fluorcarbon, mod.	-20°C to +200°C	Fuel, ethanol, vegetable oil
NBR	Nitril-Butadien	-25°C to +120°C	Oils, mineral greases
EPDM	Ethylen-Propylen-Dien	-50°C to +150°C	Break fluids

Each coupling half is laser-labelled with Part-Nr. and sealing material.

4. Hydraulic ports

The hydraulic connection is effected by male thread with conical seal 37° according to MS 33656 (standard) or MS 33657 (bulkhead version).

Size	Nominal diameter	Threads
03	3mm	3/8-24 UNF or 7/16-20 UNF
05	5mm	7/16-20 UNF or 9/16-18 UNF
08	8mm	9/16-18 UNF or 3/4 -16 UNF

→ Of course any other connector style can be realised on request.

5. Tests and certifications

Bayonet Type Quick Disconnect Couplings were tested according to FIA regulations, technical list No. 5. The following characteristics are covered by these tests:

- Burst pressure, up to 600bar (dependent on the size)
- Zero leakage (external), tested with pressurised couplings
- fluid loss while uncoupling and coupling at pressurised system

Test fluid: Calibration Fluid MIL C 7024, Type II

All these tests were performed in both coupled and uncoupled condition and were passed without any restrictions. Several qualification tests according to MIL-G are in preparation.

6. Recommendations

SF Motorsporttechnik Disconnect Couplings are manufactured only from high-strength materials with certification. All parts are produced to meet our highest requirements regarding tolerances and appearance. Each coupling is assembled according to strict specifications.

So these couplings of the Pull Type Series are in use at several successful motorsport teams.

7. Dimensions

Please notice that only one type of each size and half of the couplings is shown. Please ask for the datasheets for your required types.

7. Dimensions (Conclusion)

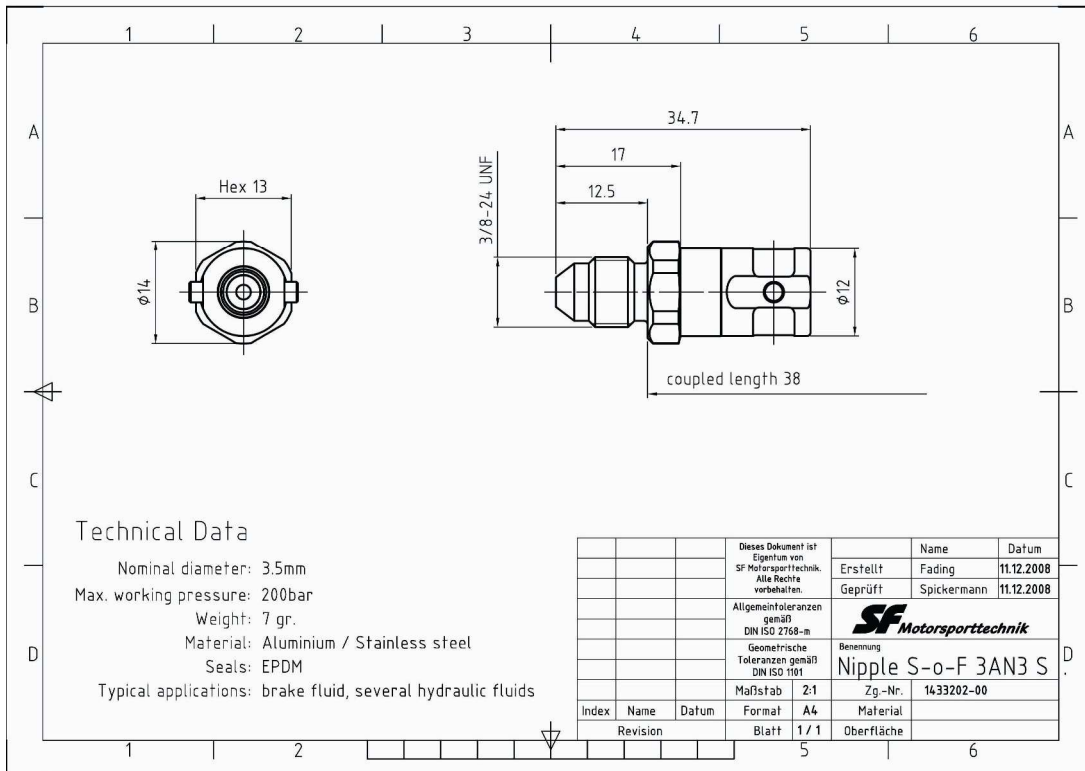
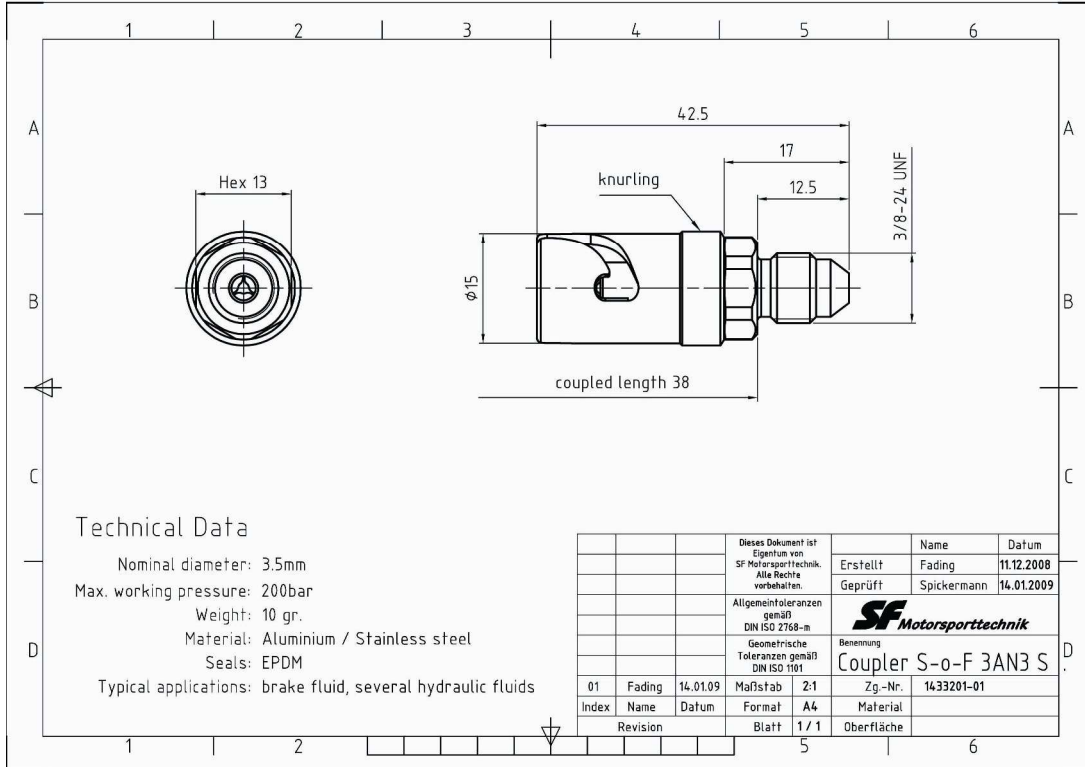

7. Dimensions (Conclusion)

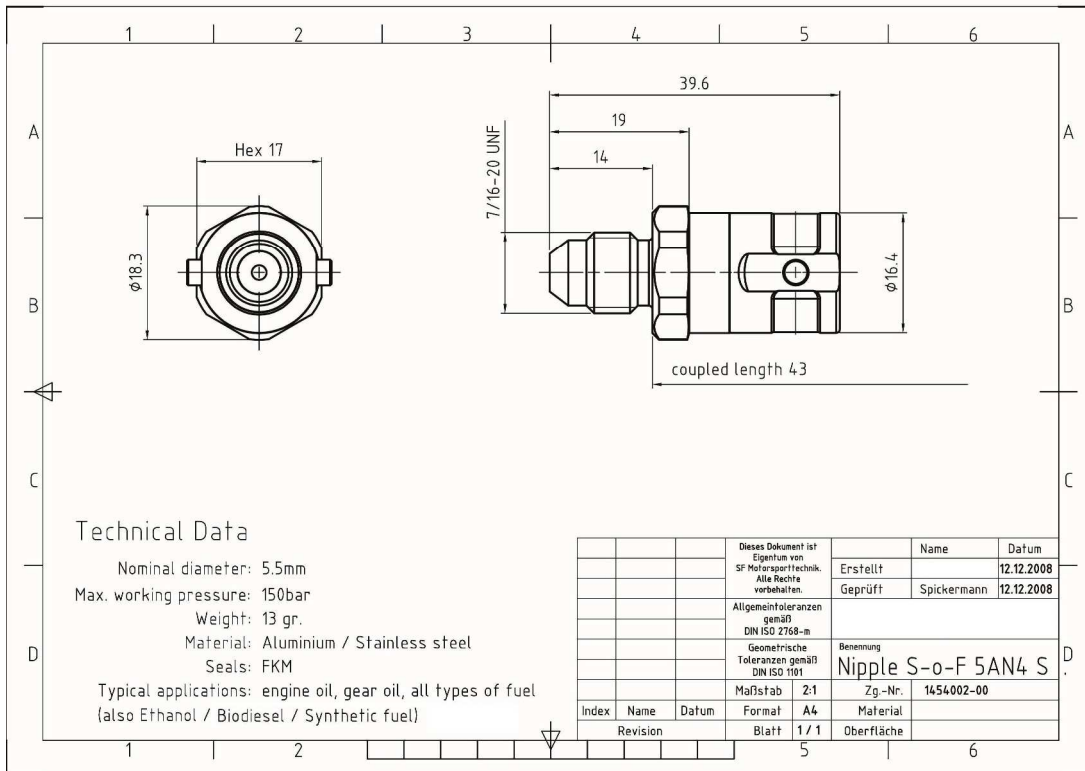
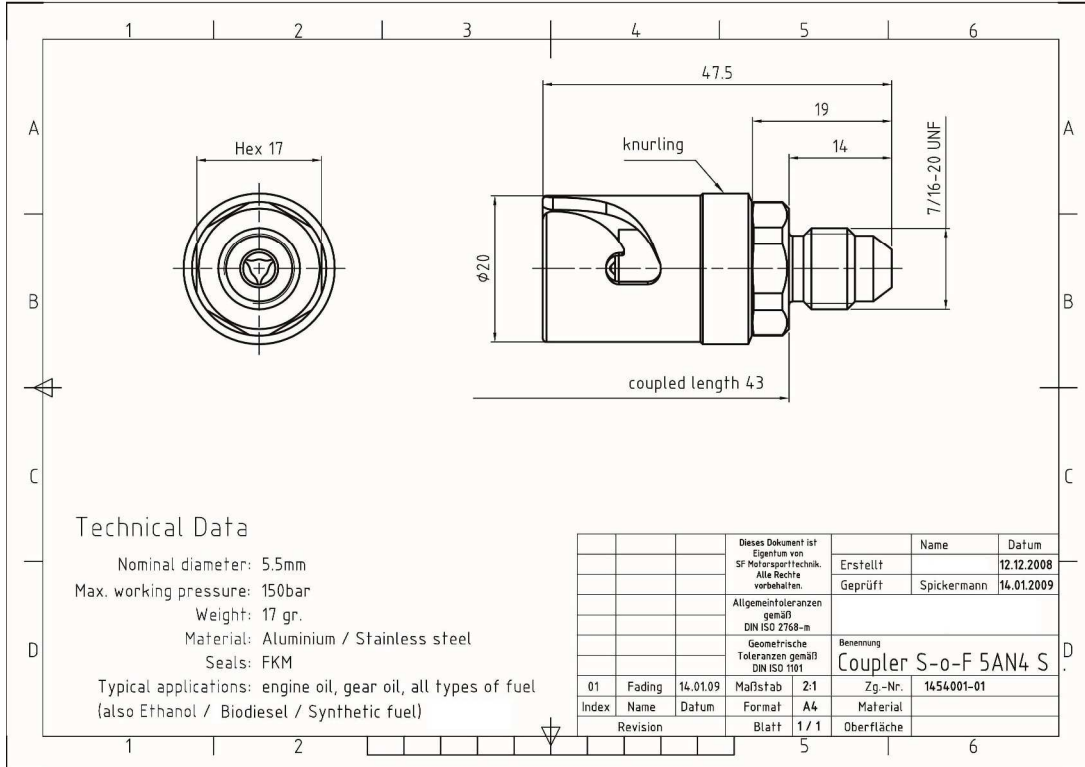

8. Flow Data

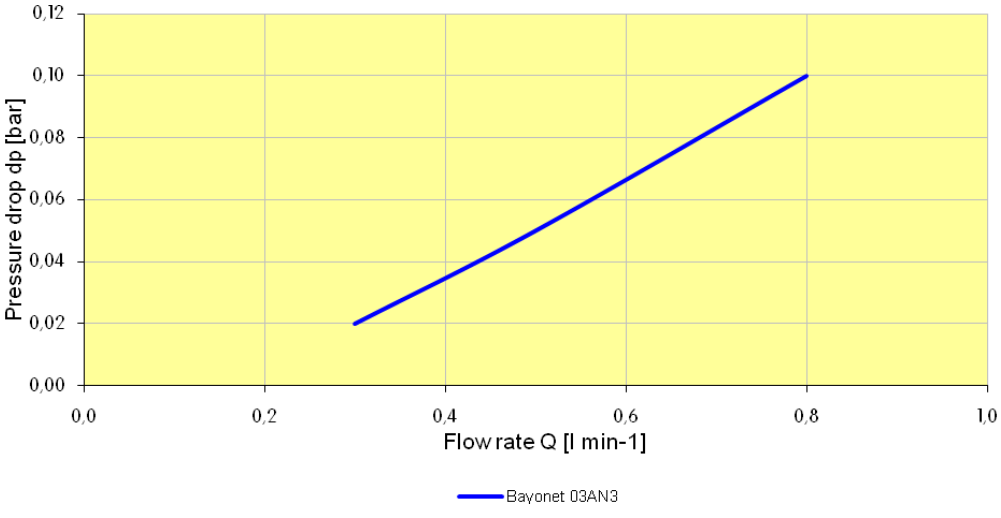
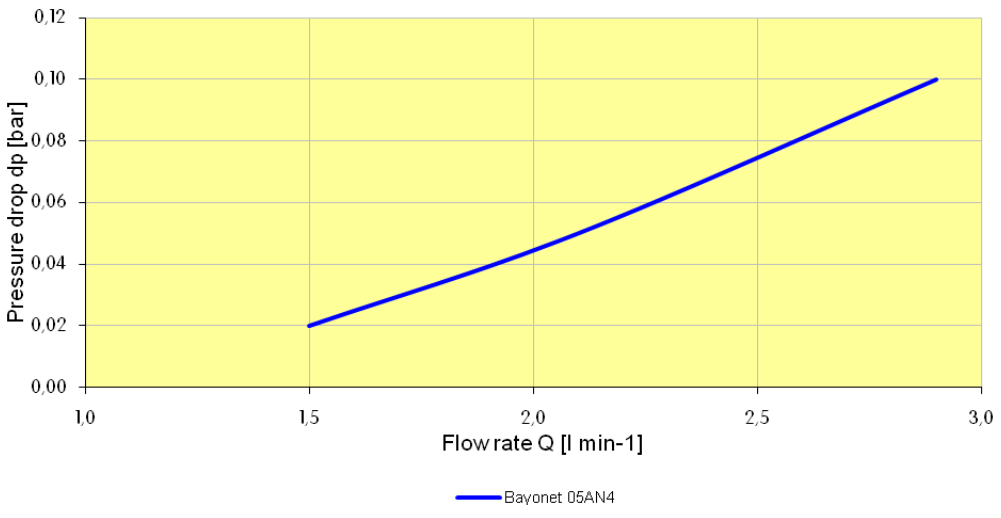
<p>Technical information</p>		
 <p style="text-align: center;">— Bayonet 03AN3</p>	<p>Product: QDV Bayonet Type</p> <p>Size - Thread 03 – AN3</p> <p>Coupler: BS03D03E</p> <p>Nipple: BP03D03E</p> <p>Flow direction: Coupler → Nipple</p> <p>Test fluid: Water</p> <p>Flow meter: PE 5 I - Kern 150</p> <p>Pressure gauge: Suku NG160, Kl. 0,6</p> <p>Annotation: Cv = 0,17</p>	
<p>Date: 03.12.2008</p>	<p>Pressure drop – Flow rate, QDV Bayonet Type NW3-AN3</p>	<p>M. Spickermann</p>
<p>Technical information</p>		
 <p style="text-align: center;">— Bayonet 05AN4</p>	<p>Product: QDV Bayonet Type</p> <p>Size - Thread 05 - AN4</p> <p>Coupler: BS05D04F</p> <p>Nipple: BP05D04F</p> <p>Flow direction: Coupler → Nipple</p> <p>Test fluid: Water</p> <p>Flow meter: PE 5 I - Kern 150</p> <p>Pressure gauge: Suku NG160, Kl. 0,6</p> <p>Annotation: Cv = 0,65</p>	
<p>Date: 03.12.2008</p>	<p>Pressure drop – Flow rate, QDV Bayonet Type NW5-AN4</p>	<p>M. Spickermann</p>

8. Flow Data (Conclusion)

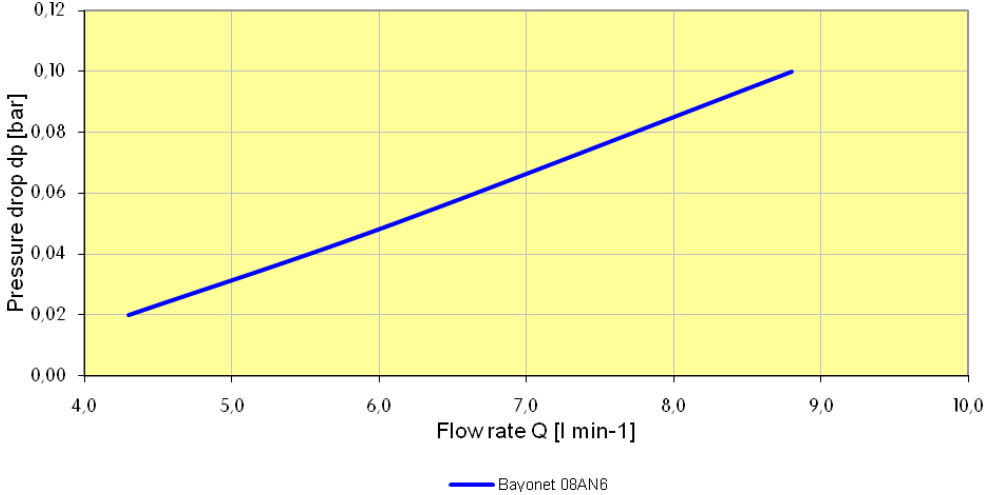
<p>Technical information</p>		
 <p>Pressure drop dp [bar]</p> <p>Flowrate Q [l min-1]</p> <p>Bayonet 08AN6</p>	<p>Product: QDV Bayonet Type</p> <p>Size - Thread 08 – AN6</p> <p>Coupler: BS08D06F</p> <p>Nipple: BP08D06F</p> <p>Flow direction: Coupler → Nipple</p> <p>Test fluid: Water</p> <p>Flow meter: PE 10 I - Kern 150</p> <p>Pressure gauge: Suku NG160, Kl. 0,6</p> <p>Annotation: Cv = 1,95</p>	
<p>Date: 03.12.2008</p>	<p>Pressure drop – Flow rate, QDV Bayonet Type NW8-AN6</p>	<p>M. Spickermann</p>